

PROJECT: 41665.11B

CONTRACT: DM00280

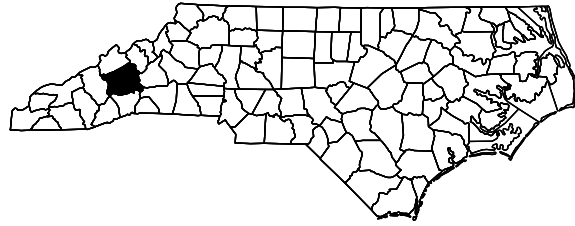

STATE OF NORTH CAROLINA
DIVISION OF HIGHWAYS

BUNCOMBE COUNTY

STATE	STATE PROJECT REFERENCE NO.	SHEET NO.	TOTAL SHEETS
N.C.	----	1	
STATE PROJ. NO.	F.A. PROJ. NO.	DESCRIPTION	
41665.11B	-	P.E.	
41665.11B	-	CONST.	

LOCATION:

BUNCOMBE COUNTY:

BRIDGE #242 ON NC-191 (BREVARD RD) OVER I-26 & I-240

TYPE OF WORK:

BRIDGE PRESERVATION - CONCRETE DECK WEARING SURFACE OVERLAY



VICINITY MAP - BUNCOMBE CO.

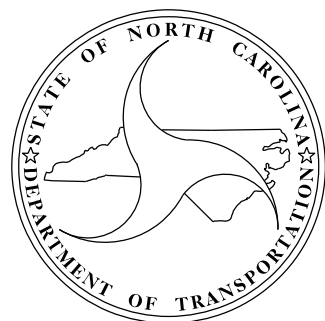

DESIGN DATA

BUNCOMBE COUNTY
#242 ADT 2014 = 8300

PROJECT LENGTH

BUNCOMBE COUNTY
#242 = 0.038 MILE

Prepared in the Office of:
**DEPARTMENT OF TRANSPORTATION
DIVISION OF HIGHWAYS**
STRUCTURES MANAGEMENT UNIT - PRESERVATION & REPAIR GROUP
1000 BIRCH RIDGE DR. RALEIGH, N.C. 27610

TIMOTHY M. SHERRILL, P.E.
PROJECT ENGINEER

2018 STANDARD SPECIFICATIONS

LETTING DATE:
APRIL 17, 2019

DocuSigned by:

Timothy M. Sherrill
AD5081007194000



2/26/2019

TIMOTHY M. SHERRILL, P.E.
PROJECT DESIGN ENGINEER

TOTAL BILL OF MATERIAL

INCIDENTAL MILLING	ASPHALT CONCRETE SURFACE COURSE S9.5C	ASPHALT BINDER FOR PLANT MIX	GROOVING BRIDGE FLOORS	CLASS II SURFACE PREPARATION	CLASS III SURFACE PREPARATION	VOLUMETRIC MIXER	SCARIFYING BRIDGE DECK	CONCRETE WEARING SURFACE
SO. YDS.	TONS	TONS	SO. FT.	SO. YDS.	SO. YDS.	LS	SO. YDS.	SO. FT.
156	13	0.75	3,719	28.5	5	LS	464	4179

PROJECT NO. 41665.11B
BUNCOMBE COUNTY
 BRIDGE NO. 242

DocuSigned by:

Timothy M. Sherrill

AD50B1D977494CC



2/26/2019

STATE OF NORTH CAROLINA
 DEPARTMENT OF TRANSPORTATION
 RALEIGH

TOTAL
 BILL OF MATERIAL

REVISIONS						SHEET NO.
NO.	BY:	DATE:	NO.	BY:	DATE:	S-1
1			3			TOTAL SHEETS
2			4			9

DRAWN BY : L. B. LACORTE DATE : 03/18
 CHECKED BY : T. M. SHERRILL DATE : 02/19

*****SYSTEM*****
 *****DCN*****
 *****USERNAME*****

NOTE:
 THE PROFILE INFORMATION AND ROAD
 CLEARANCES ARE TAKEN FROM THE
 ORIGINAL PLANS AND THE ROUTINE
 INSPECTION REPORT DATED SEP. 06, 2014

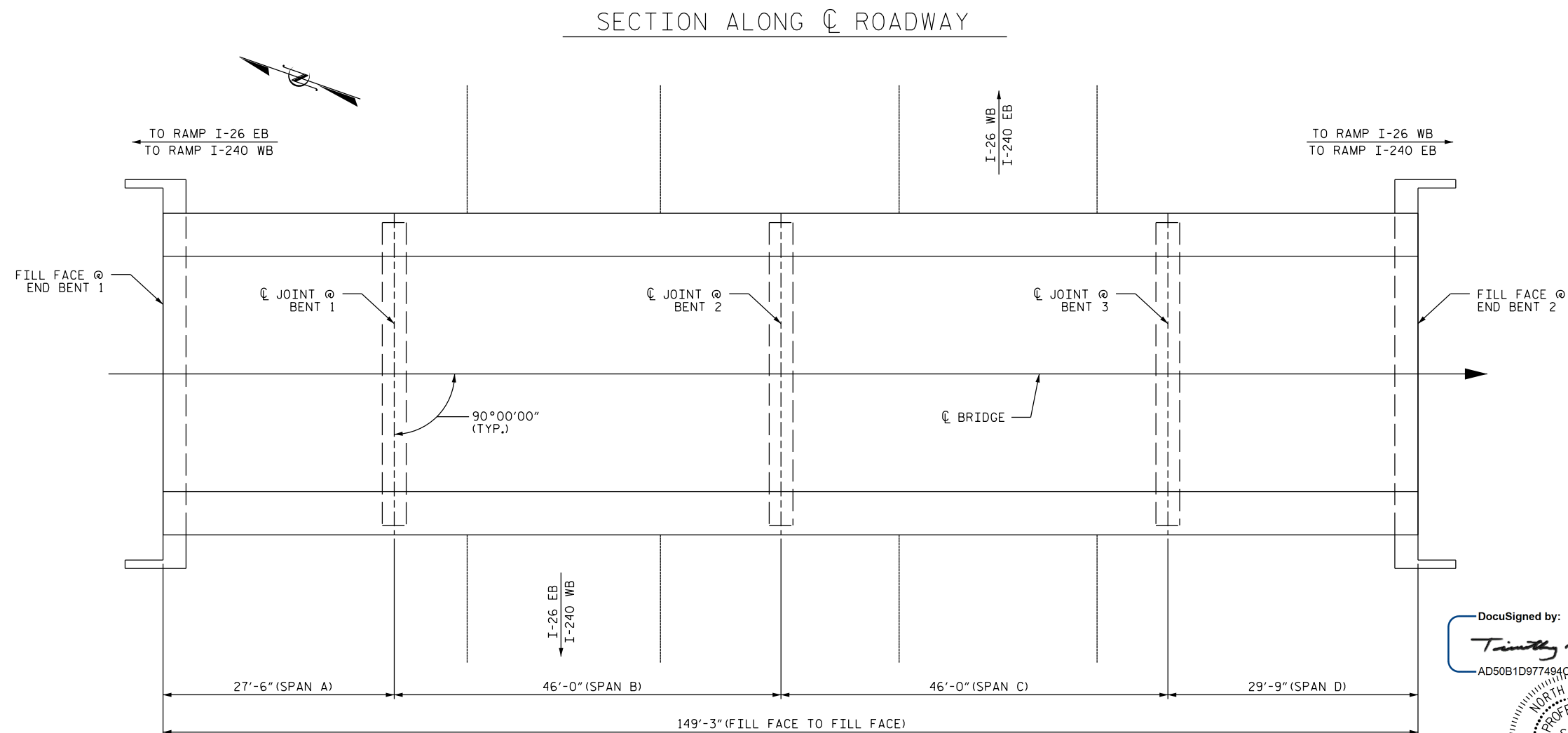
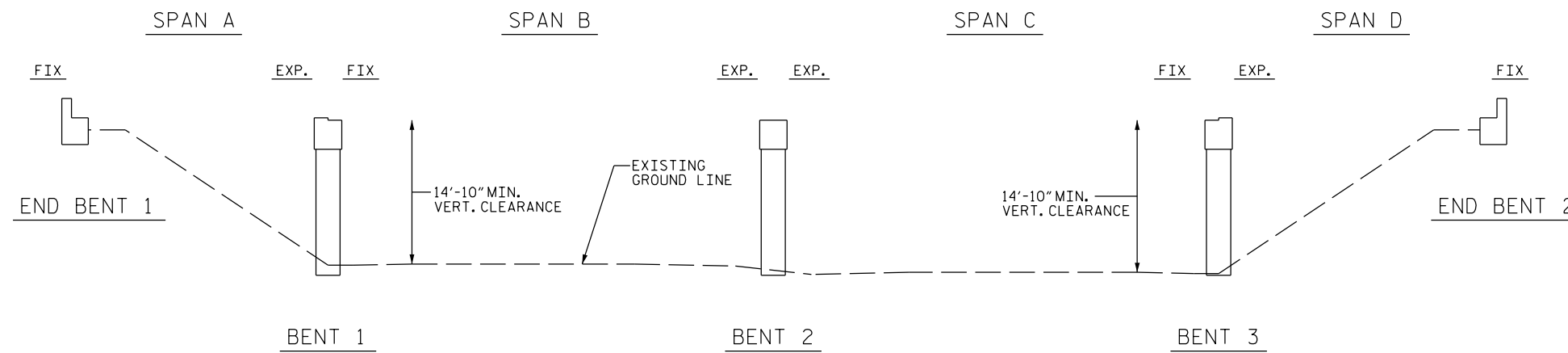

PROJECT NO. 41665.11B
 BUNCOMBE COUNTY
 BRIDGE NO. 242

DocuSigned by:
 Timothy M. Sherrill

AD50B1D977484CC

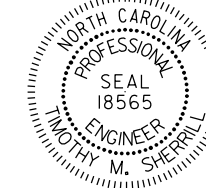

2/26/2019

STATE OF NORTH CAROLINA
 DEPARTMENT OF TRANSPORTATION
 RALEIGH

GENERAL DRAWING
 BRIDGE 242 ON
 NC-191 (BREVARD RD)
 OVER I-26 & I-240

REVISIONS						SHEET NO.
NO.	BY:	DATE:	NO.	BY:	DATE:	S-2
1			3			TOTAL SHEETS
2			4			9

DRAWN BY : L. B. LACORTE DATE : 03/18
 CHECKED BY : T. M. SHERRILL DATE : 02/19

*****SYSTEM*****
 *****DCN*****
 *****USERNAME*****



LOCATION SKETCH

INFORMATION INDICATED ON THE LOCATION SKETCH SHALL BE CONSIDERED GENERAL INFORMATION, ONLY. THE CONTRACTOR SHALL CONFIRM, THROUGH OTHER SOURCES, SPECIFIC INFORMATION REGARDING THE BRIDGES, ROADWAYS, UTILITIES, THE SURROUNDING AREA, AND ANY OTHER ASPECTS THAT MAY BE NECESSARY TO PERFORM AND COMPLETE THE PROJECT.

NOTES

EXISTING DIMENSIONS AND BRIDGE CONDITION ARE FROM THE BEST INFORMATION AVAILABLE. THE CONTRACTOR SHALL FIELD VERIFY THE INFORMATION SHOWN ON THE PLANS AND NOTIFY THE ENGINEER IF ACTUAL DIMENSIONS AND CONDITIONS DIFFER.

IT IS THE CONTRACTOR'S RESPONSIBILITY TO FOLLOW ALL STATE AND FEDERAL SAFETY REQUIREMENTS.

FOR CONCRETE WEARING SURFACE, SEE SPECIAL PROVISIONS.

ROADWAY MILLING IS INCLUDED TO ENSURE A SMOOTH TRANSITION ONTO THE BRIDGE FLOOR. THE CONTRACTOR SHALL MILL AS REQUIRED TO PROVIDE A SMOOTH TRANSITION TO THE ROADWAY AT BOTH ENDS OF THE BRIDGE.

THE CONTRACTOR SHALL PROVIDE A METHOD OF HANDLING UNEXPECTED BLOW THROUGH OF THE DECK.

FOR SCARIFYING BRIDGE DECK, AND CLASS II AND CLASS III SURFACE PREPARATION, SEE OVERLAY SURFACE PREPARATION SPECIAL PROVISION.

EXISTING JOINTS AND DECK DRAINS SHALL BE SEALED PRIOR TO BEGINNING REPAIR OF BRIDGE DECKS.

FOR CONTROL OF TRAFFIC AND LIMITS ON PHASING OF CONSTRUCTION, SEE TRANSPORTATION MANAGEMENT PLANS.

LONGITUDINAL CONSTRUCTION JOINTS OF OVERLAYS SHALL BE LOCATED ALONG THE CENTERLINE OR EDGE OF TRAVEL LANES.

FOR SUBMITTAL OF WORKING DRAWINGS, SEE SPECIAL PROVISIONS.

FOR FALSEWORK AND FORMWORK, SEE SPECIAL PROVISIONS.

FOR GROUT FOR STRUCTURES, SEE SPECIAL PROVISIONS.

FOR CRANE SAFETY, SEE SPECIAL PROVISIONS.

FOR CONCRETE FOR DECK REPAIR, SEE SPECIAL PROVISIONS.

FOR VOLUMETRIC MIXER, SEE SPECIAL PROVISIONS.

PROJECT NO. 41665.11B
 BUNCOMBE COUNTY
 BRIDGE NO. 242

DocuSigned by:
Timothy M. Sherrill
 AD50B1D977494CC

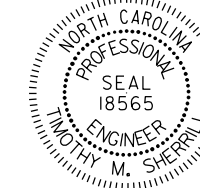

2/26/2019

STATE OF NORTH CAROLINA
 DEPARTMENT OF TRANSPORTATION
 RALEIGH

GENERAL DRAWING
 FOR BRIDGE 242 ON
 NC-191 (BREVARD RD)
 OVER I-26 & I-240

REVISIONS						SHEET NO.
NO.	BY:	DATE:	NO.	BY:	DATE:	TOTAL SHEETS
1			3			9
2			4			

DRAWN BY : L. B. LACORTE DATE : 03/18
 CHECKED BY : T. M. SHERRILL DATE : 02/19

*****SYSTEM*****
 *****DCN*****
 *****USERNAME*****

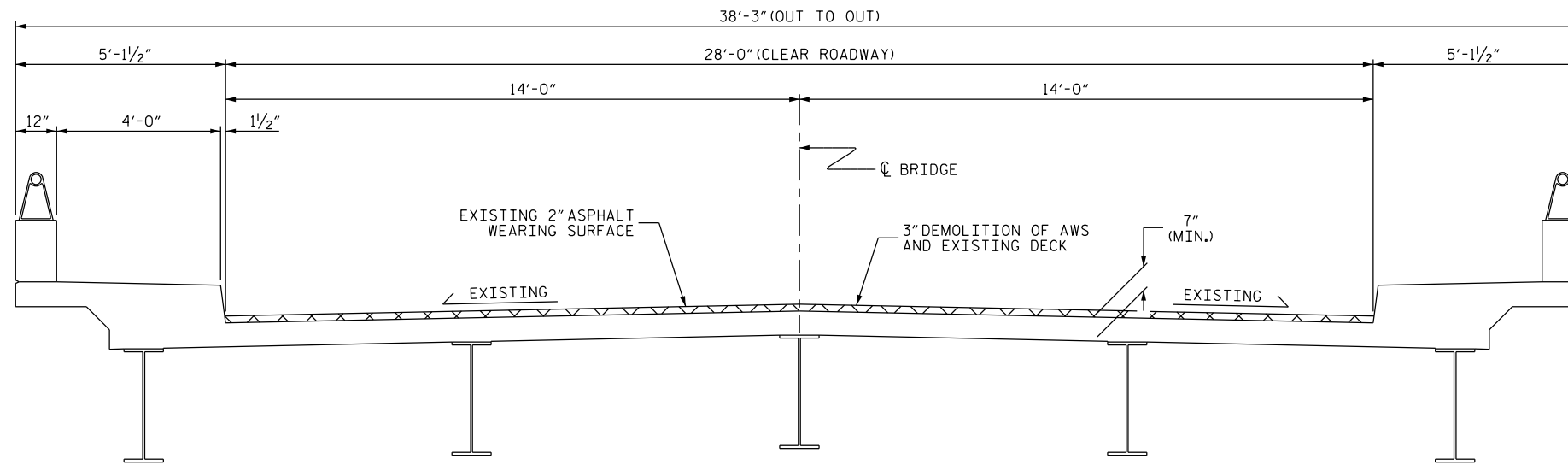

TYPICAL SECTION
(EXISTING)

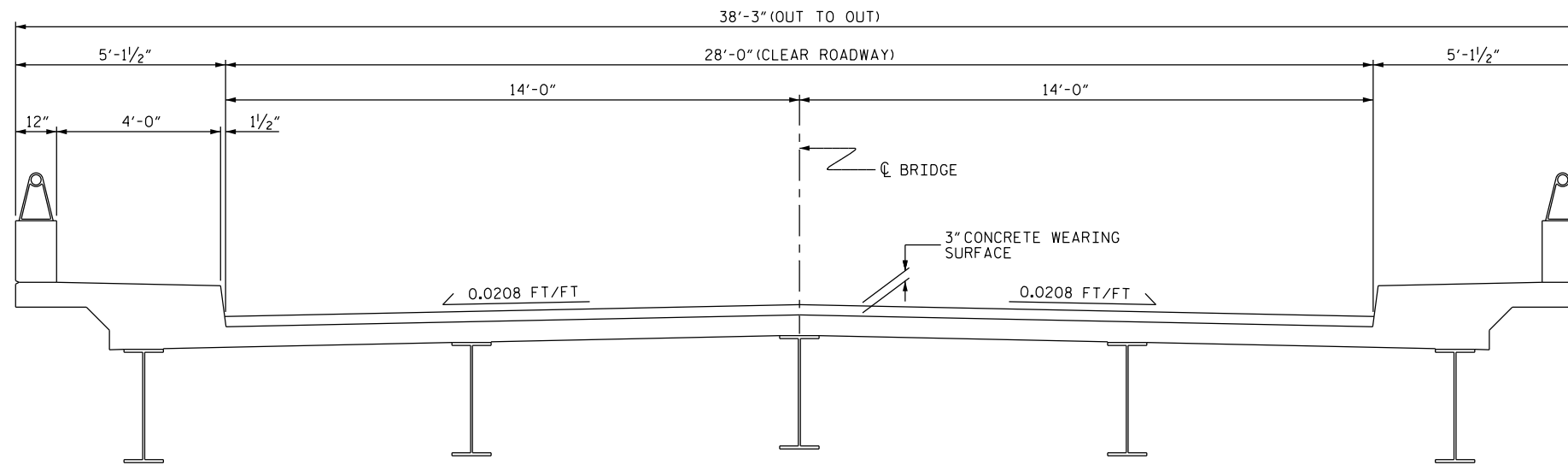

TYPICAL SECTION
(PROPOSED)

PROJECT NO. 41665.11B
 BUNCOMBE COUNTY
 BRIDGE NO. 242

DocuSigned by:

Timothy M. Sherrill

AD50B1D977494CC

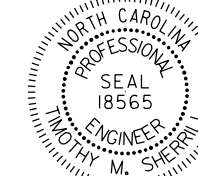

2/26/2019

STATE OF NORTH CAROLINA
 DEPARTMENT OF TRANSPORTATION
 RALEIGH

TYPICAL SECTION

REVISIONS						SHEET NO.
NO.	BY:	DATE:	NO.	BY:	DATE:	S-4
1			3			TOTAL SHEETS
2			4			9

DRAWN BY : L. B. LACORTE DATE : 02/18
 CHECKED BY : T. M. SHERRILL DATE : 02/19

*****SYSTEM*****
 *****DCN*****
 *****USERNAME*****

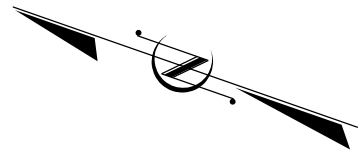

← TO RAMP I-26 EB
TO RAMP I-240 WB

TO RAMP I-26 WB →
TO RAMP I-240 EB

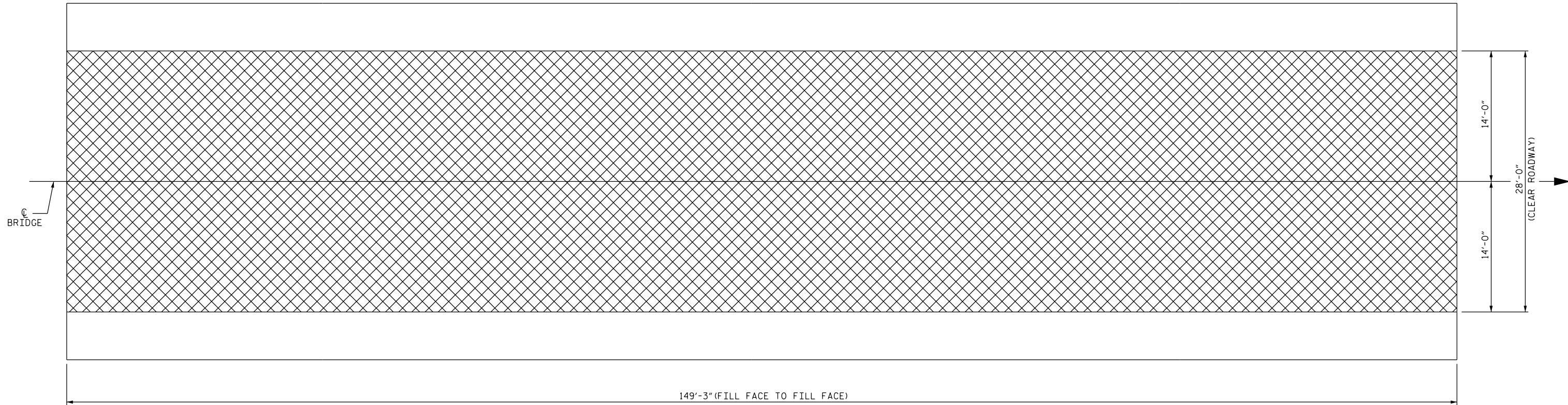

149'-3" (FILL FACE TO FILL FACE)

 DECK SCARIFICATION

PLAN

PROJECT NO. 41665.11B
BUNCOMBE COUNTY
BRIDGE NO. 242

DocuSigned by:
Trinity M. Spill
AD50B1D977494CC

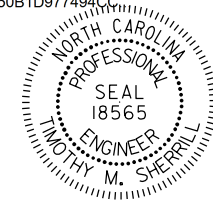

2/26/2019

STATE OF NORTH CAROLINA
DEPARTMENT OF TRANSPORTATION
RALEIGH
**OVERALL
SURFACE PREPARATION
PLAN**

DRAWN BY : L. B. LACORTE DATE : 02/18
CHECKED BY : T. M. SHERRILL DATE : 03/19

*****SYSTEM*****
*****DCN*****
*****USERNAME*****

REVISIONS						SHEET NO.
NO.	BY:	DATE:	NO.	BY:	DATE:	S-5
1			3			TOTAL SHEETS
2			4			9

SUMMARY OF QUANTITIES

TOP OF DECK REPAIRS

	ESTIMATE	ACTUAL
SCARIFYING BRIDGE DECK	465 SY	
CLASS II SURFACE PREPARATION	* 28.5 SY	
CLASS III SURFACE PREPARATION	* 5 SY	
CONCRETE FOR DECK REPAIR	* 130 CF	

* BECAUSE OF THE PRESENCE OF THE EXISTING ASPHALT WEARING SURFACE, QUANTITIES OF CLASS II AND CLASS III SURFACE PREPARATION AND CONCRETE FOR DECK REPAIR ARE UNKNOWN. QUANTITIES INDICATED ARE ESTIMATED FOR ESTABLISHING UNIT BID PRICES.

AFTER SCARIFICATION OF THE EXISTING ASPHALT WEARING SURFACE AND THE EXISTING CONCRETE DECK AS INDICATED, EXISTING DECK PATCHES SHALL BE REMOVED AND REPAIRED PRIOR TO PLACEMENT OF THE CONCRETE WEARING SURFACE OVERLAY. THE ENGINEER SHALL REVIEW THE PREPARED DECK TO DETERMINE THE AREAS THAT WILL REQUIRE CLASS II OR CLASS III REPAIRS. REPAIR AREAS THAT ARE FULL DECK DEPTH SHALL BE CONSIDERED CLASS III.

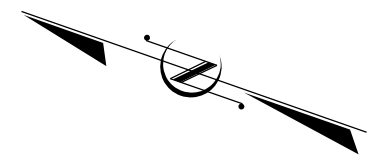

TO RAMP I-26 EB
TO RAMP I-240 WB

TO RAMP I-26 WB
TO RAMP I-240 EB

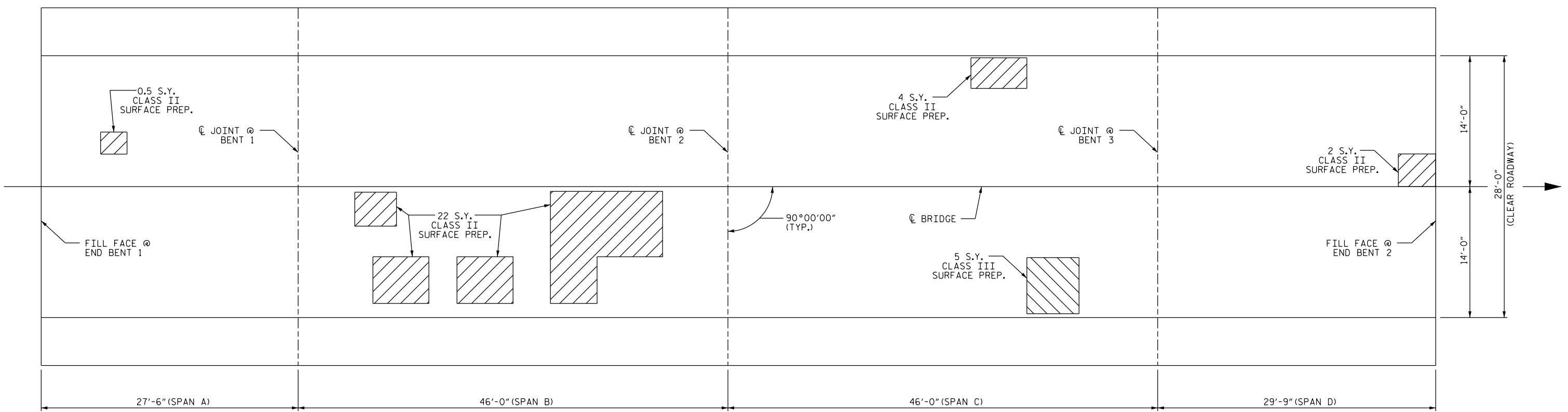

CLASS II SURFACE PREPARATION
 CLASS III SURFACE PREPARATION

PLAN

PROJECT NO. 41665.11B
BUNCOMBE COUNTY
BRIDGE NO. 242

DocuSigned by:
Timothy M. Sherrill
AD50B1D977494CC...

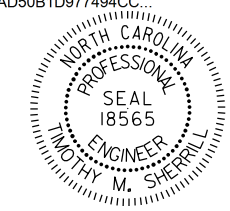

2/26/2019

STATE OF NORTH CAROLINA
DEPARTMENT OF TRANSPORTATION
RALEIGH

SURFACE PREPARATION

REVISIONS						SHEET NO.
NO.	BY:	DATE:	NO.	BY:	DATE:	S-6
1			3			TOTAL SHEETS
2			4			9

DRAWN BY : L. B. LACORTE DATE : 02/18
CHECKED BY : T. M. SHERRILL DATE : 03/19

*****SYSTEM*****
*****DCN*****
*****USERNAME*****

NOTES

PROVIDE SAW CUT AS SOON AS PRACTICAL AFTER SETTING OF CONCRETE, BUT NO LATER THAN 4 HOURS AFTER COMPLETION OF CONCRETE PLACEMENT.

3/4" BACKER ROD SHALL BE CLOSED CELL EXPANDED POLYETHYLENE FOAM TYPE L. NO SEPARATE PAYMENT FOR LABOR, MATERIALS, AND EQUIPMENT NEEDED TO CONSTRUCT CONCRETE JOINT SEALS SHALL BE MADE. COSTS FOR THIS WORK SHALL BE INCLUDED IN THE SEVERAL PAY ITEMS.

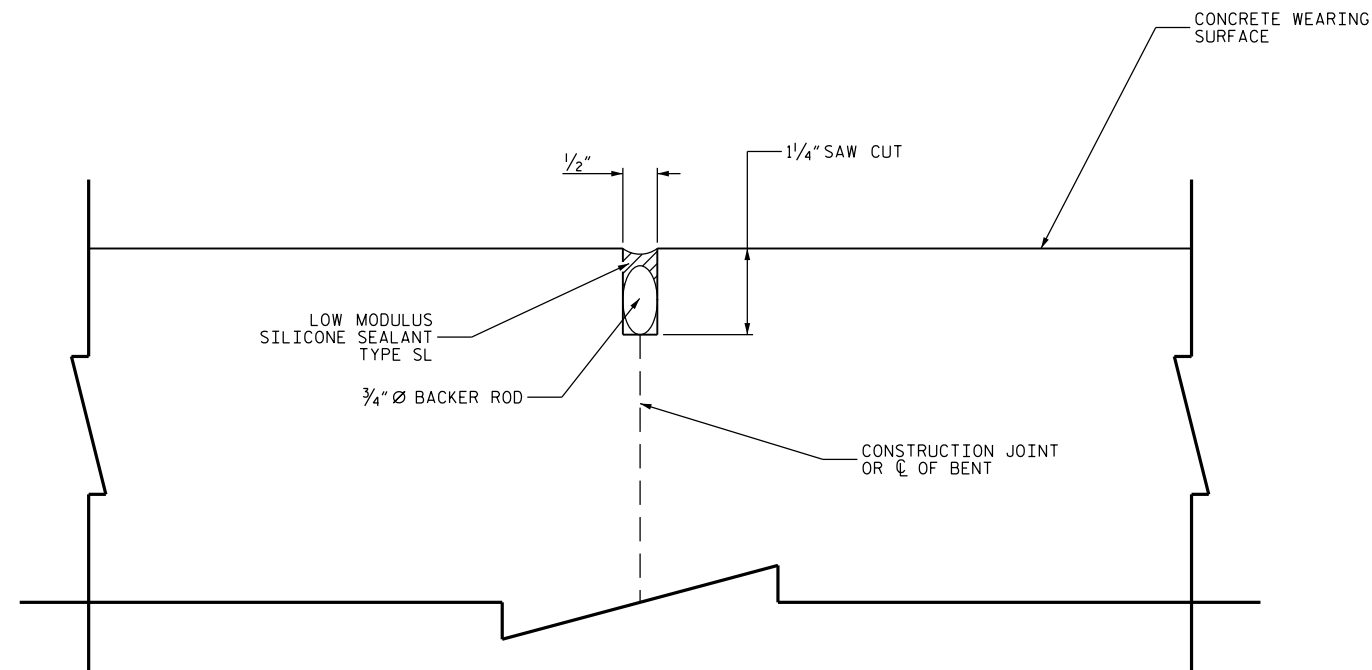

DETAIL
(TYPICAL)

PROJECT NO. 41665.11B
BUNCOMBE COUNTY
 BRIDGE NO. 242

STATE OF NORTH CAROLINA
 DEPARTMENT OF TRANSPORTATION
 RALEIGH

JOINT DETAILS

REVISIONS						SHEET NO.
NO.	BY:	DATE:	NO.	BY:	DATE:	TOTAL SHEETS
1			3			9
2			4			

DRAWN BY : L. B. LACORTE DATE : 03/18
 CHECKED BY : T. M. SHERRILL DATE : --

NOTES:

INCIDENTAL MILLING - EXISTING APPROACH ASPHALT PAVING TO BE MILLED AS NECESSARY TO ATTAIN MINIMUM 1/2" DEPTH OF NEW ASPHALT PAVING. PROVIDE NEW ASPHALT PAVING THICKNESS TO CREATE A SMOOTH TRANSITION BETWEEN THE ROADWAY AND THE BRIDGE DECK. NEW ASPHALT PAVING THICKNESS MAY EXCEED 1/2" DUE TO SETTLEMENT OF THE EXISTING APPROACH ASPHALT PAVING.

LAYOUT OF APPROACH ROADWAY IS FOR ILLUSTRATIVE PURPOSES ONLY. ESTIMATED QUANTITIES ARE APPROXIMATE. PAYMENT OF MILLING AND NEW APPROACH ASPHALT WILL BE FOR THE ACTUAL QUANTITIES MILLED AND PLACED.

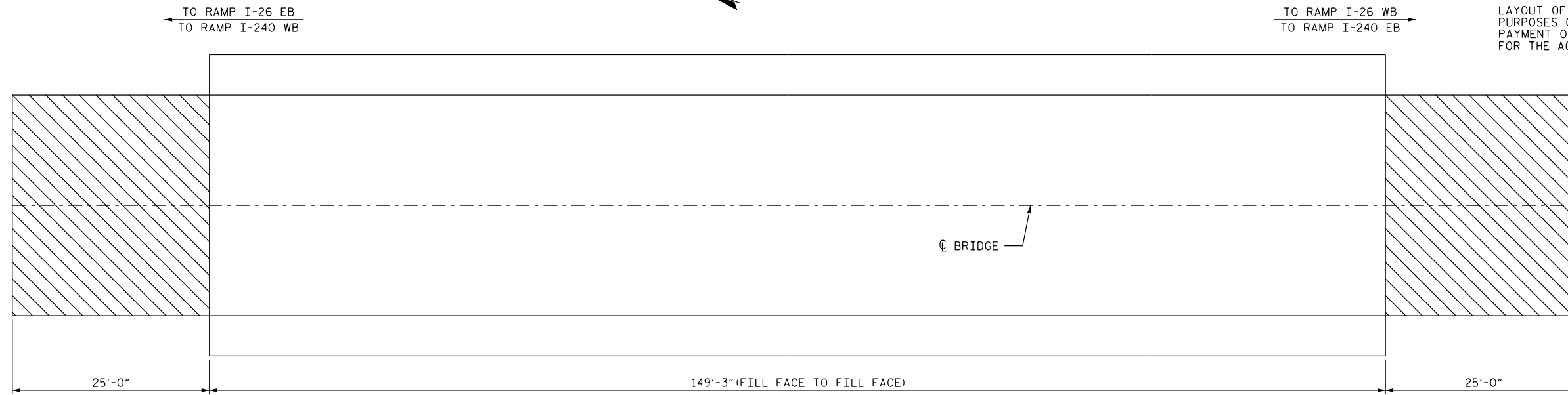

PLAN

INCIDENTAL MILLING

SUMMARY OF QUANTITIES

	ESTIMATE	ACTUAL
INCIDENTAL MILLING	156 SQ. YDS.	
ASPHALT CONCRETE SURFACE COURSE, TYPE S9.5B	13 TONS	

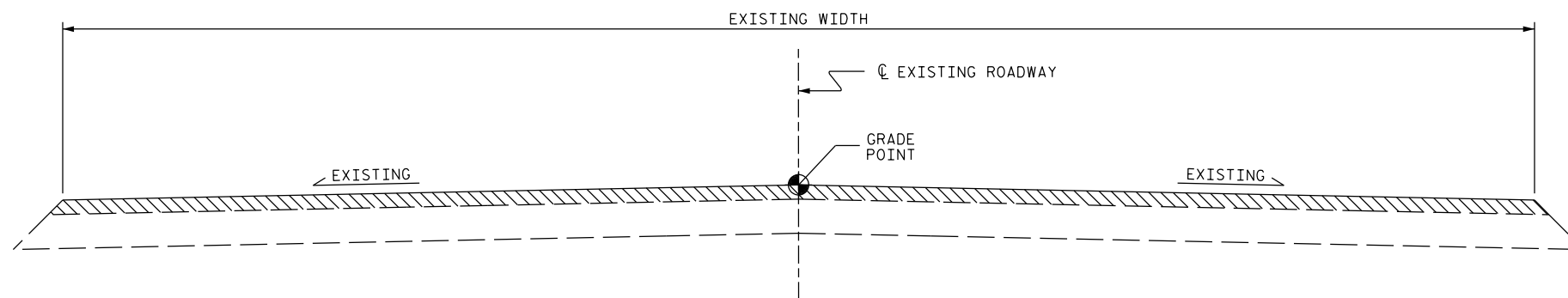

TYPICAL ROADWAY MILLING SECTION

C1 PROPOSED VARIABLE DEPTH ASPHALT CONCRETE SURFACE COURSE, TYPE S9.5B AT AN AVERAGE RATE OF 112 LBS. PER SQ. YD. PER 1" DEPTH. TO BE PLACED IN LAYERS NOT LESS THAN 1/2" IN DEPTH OR GREATER THAN 2" IN DEPTH.

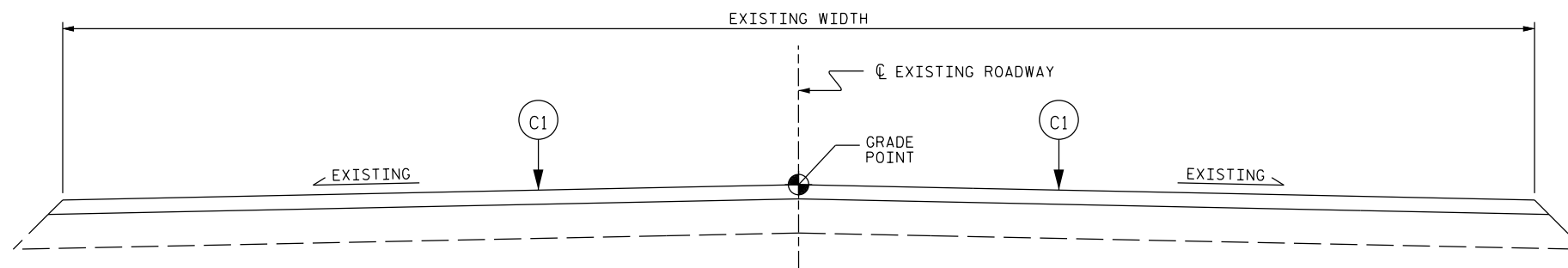

TYPICAL PROPOSED ROADWAY SECTION

PROJECT NO. ---
 BUNCOMBE COUNTY
 BRIDGE NO. 242

DocuSigned by:
Timothy M. Sherrill
 AD50B1D977494CC

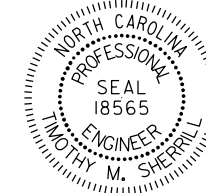

2/26/2019

STATE OF NORTH CAROLINA
 DEPARTMENT OF TRANSPORTATION
 RALEIGH

APPROACH MILLING AND TYPICAL ROADWAY SECTION

REVISIONS						SHEET NO.
NO.	BY:	DATE:	NO.	BY:	DATE:	TOTAL SHEETS
1			3			9
2			4			

DRAWN BY : L. B. LACORTE DATE : 02/18
 CHECKED BY : T. M. SHERRILL DATE : 03/19

*****SYSTEM*****
 *****DCN*****
 *****USERNAME*****

STANDARD NOTES

DESIGN DATA:

SPECIFICATIONS	-----	A.A.S.H.T.O. (CURRENT)
LIVE LOAD	-----	SEE PLANS
IMPACT ALLOWANCE	-----	SEE A.A.S.H.T.O.
STRESS IN EXTREME FIBER OF		
STRUCTURAL STEEL - AASHTO M270 GRADE 36	-	20,000 LBS. PER SQ. IN.
- AASHTO M270 GRADE 50W	-	27,000 LBS. PER SQ. IN.
- AASHTO M270 GRADE 50	-	27,000 LBS. PER SQ. IN.
REINFORCING STEEL IN TENSION		
GRADE 60	--	24,000 LBS. PER SQ. IN.
CONCRETE IN COMPRESSION	-----	1,200 LBS. PER SQ. IN.
CONCRETE IN SHEAR	-----	SEE A.A.S.H.T.O.
STRUCTURAL TIMBER - TREATED OR		
UNTREATED - EXTREME FIBER STRESS	-----	1,800 LBS. PER SQ. IN.
COMPRESSION PERPENDICULAR TO GRAIN OF TIMBER	-----	375 LBS. PER SQ. IN.
EQUIVALENT FLUID PRESSURE OF EARTH	-----	30 LBS. PER CU. FT.
		(MINIMUM)

MATERIAL AND WORKMANSHIP:

EXCEPT AS MAY OTHERWISE BE SPECIFIED ON PLANS OR IN THE SPECIAL PROVISIONS, ALL MATERIAL AND WORKMANSHIP SHALL BE IN ACCORDANCE WITH THE 2018 "STANDARD SPECIFICATIONS FOR ROADS AND STRUCTURES" OF THE N. C. DEPARTMENT OF TRANSPORTATION.

STEEL SHEET PILING FOR PERMANENT OR TEMPORARY APPLICATIONS SHALL BE HOT ROLLED.

CONCRETE:

UNLESS OTHERWISE REQUIRED ON PLANS, CLASS A CONCRETE SHALL BE USED FOR ALL PORTIONS OF ALL STRUCTURES WITH THE EXCEPTION THAT: CLASS AA CONCRETE SHALL BE USED IN BRIDGE SUPERSTRUCTURES, ABUTMENT BACKWALLS, AND APPROACH SLABS; AND CLASS B CONCRETE SHALL BE USED FOR SLOPE PROTECTION AND RIP RAP.

CONCRETE CHAMFERS:

UNLESS OTHERWISE NOTED ON THE PLANS, ALL EXPOSED CORNERS ON STRUCTURES SHALL BE CHAMFERED 3/4" WITH THE FOLLOWING EXCEPTIONS: TOP CORNERS OF CURBS MAY BE ROUNDED TO 1-1/2" RADIUS WHICH IS BUILT INTO CURB FORMS; CORNERS OF TRANSVERSE FLOOR EXPANSION JOINTS SHALL BE ROUNDED WITH A 1/4" FINISHING TOOL UNLESS OTHERWISE REQUIRED ON PLANS; AND CORNERS OF EXPANSION JOINTS IN THE ROADWAY FACES AND TOPS OF CURBS AND SIDEWALKS SHALL BE ROUNDED TO A 1/4" RADIUS WITH A FINISHING STONE OR TOOL UNLESS OTHERWISE REQUIRED ON PLANS.

DOWELS:

DOWELS WHEN INDICATED ON PLANS AS FOR CULVERT EXTENSIONS, SHALL BE EMBEDDED AT LEAST 12" INTO THE OLD CONCRETE AND GROUTED INTO PLACE WITH 1:2 CEMENT MORTAR.

ALLOWANCE FOR DEAD LOAD DEFLECTION, SETTLEMENT, ETC. IN CASTING SUPERSTRUCTURES:

BRIDGES SHALL BE BUILT ON THE GRADE OR VERTICAL CURVE SHOWN ON PLANS. SLABS, CURBS AND PARAPETS SHALL CONFORM TO THE GRADE OR CURVE. ALL DIMENSIONS WHICH ARE GIVEN IN SECTION AND ARE AFFECTED BY DEAD LOAD DEFLECTIONS ARE DIMENSIONS AT CENTER LINE OF BEARING UNLESS OTHERWISE NOTED ON PLANS. IN SETTING FORMS FOR STEEL BEAM BRIDGES AND PRESTRESSED CONCRETE GIRDER BRIDGES, ADJUSTMENTS SHALL BE MADE DUE TO THE DEAD LOAD DEFLECTIONS FOR THE ELEVATIONS SHOWN. WHERE BLOCKS ARE SHOWN OVER BEAMS FOR BUILDING UP TO THE SLAB, THE VERTICAL DIMENSIONS OF THE BLOCKS SHALL BE ADJUSTED BETWEEN BEARINGS TO COMPENSATE FOR DEAD LOAD DEFLECTIONS, VERTICAL CURVE ORDINATE, AND ACTUAL BEAM CAMBER. WHERE BOTTOM OF SLAB IS IN LINE WITH BOTTOM OF TOP FLANGES, DEPTH OF SLAB BETWEEN BEARINGS SHALL BE ADJUSTED TO COMPENSATE FOR DEAD LOAD DEFLECTION, VERTICAL CURVE ORDINATE, AND ACTUAL BEAM CAMBER.

IN SETTING FALSEWORK AND FORMS FOR REINFORCED CONCRETE SPANS, AN ALLOWANCE SHALL BE MADE FOR DEAD LOAD DEFLECTIONS, SETTLEMENT OF FALSEWORK, AND PERMANENT CAMBER WHICH SHALL BE PROVIDED FOR IN ADDITION TO THE ELEVATIONS SHOWN. AFTER REMOVAL OF THE FALSEWORK, THE FINISHED STRUCTURES SHALL CONFORM TO THE PROFILE AND ELEVATIONS SHOWN ON THE PLANS AND CONSTRUCTION ELEVATIONS FURNISHED BY THE ENGINEER.

DETAILED DRAWINGS FOR FALSEWORK OR FORMS FOR BRIDGE SUPERSTRUCTURE AND ANY STRUCTURE OR PARTS OF A STRUCTURE AS NOTED ON THE PLANS SHALL BE SUBMITTED TO THE ENGINEER FOR APPROVAL BEFORE CONSTRUCTION OF THE FALSEWORK OR FORMS IS STARTED.

REINFORCING STEEL:

ALL REINFORCING STEEL SHALL BE DEFORMED. DIMENSIONS RELATIVE TO PLACEMENT OF REINFORCING ARE TO CENTERS OF BARS UNLESS OTHERWISE INDICATED IN THE PLANS. DIMENSIONS ON BAR DETAILS ARE TO CENTERS OF BARS OR ARE OUT TO OUT AS INDICATED ON PLANS.

WIRE BAR SUPPORTS SHALL BE PROVIDED FOR REINFORCING STEEL WHERE INDICATED ON THE PLANS. WHEN BAR SUPPORT PIECES ARE PLACED IN CONTINUOUS LINES, THEY SHALL BE SO PLACED THAT THE ENDS OF THE SUPPORTING WIRES SHALL BE LAPPED TO LOCK LEGS ON ADJOINING PIECES.

STRUCTURAL STEEL:

AT THE CONTRACTOR'S OPTION, HE MAY SUBSTITUTE 7/8" Ø SHEAR STUDS FOR THE 3/4" Ø STUDS SPECIFIED ON THE PLANS. THIS SUBSTITUTION SHALL BE MADE AT THE RATE OF 3 - 7/8" Ø STUDS FOR 4 - 3/4" Ø STUDS, AND STUD SPACING CHANGES SHALL BE MADE AS NECESSARY TO PROVIDE THE SAME EQUIVALENT NUMBER OF 7/8" Ø STUDS ALONG THE BEAM AS SHOWN FOR 3/4" Ø STUDS BASED ON THE RATIO OF 3 - 7/8" Ø STUDS FOR 4 - 3/4" Ø STUDS. STUDS OF THE LENGTH SPECIFIED ON THE PLANS MUST BE PROVIDED. THE MAXIMUM SPACING SHALL BE 2'-0".

EXCEPT AT THE INTERIOR BEARING SUPPORTS OF CONTINUOUS BEAMS WHERE THE COVER PLATE IS IN CONTACT WITH BEARING PLATE, THE CONTRACTOR MAY, AT HIS OPTION, SUBSTITUTE FOR THE COVER PLATES DESIGNATED ON THE PLANS COVER PLATES OF THE EQUIVALENT AREA PROVIDED THESE PLATES ARE AT LEAST 5/16" IN THICKNESS AND DO NOT EXCEED A WIDTH EQUAL TO THE FLANGE WIDTH LESS 2" OR A THICKNESS EQUAL TO 2 TIMES THE FLANGE THICKNESS. THE SIZE OF FILLET WELDS SHALL CONFORM TO THE REQUIREMENTS OF THE CURRENT ANSI/AASHTO/AWS "BRIDGE WELDING CODE". ELECTROSLAG WELDING WILL NOT BE PERMITTED.

WITH THE SOLE EXCEPTION OF EDGES AT SURFACES WHICH BEAR ON OTHER SURFACES, ALL SHARP EDGES AND ENDS OF SHAPES AND PLATES SHALL BE SLIGHTLY ROUNDED BY SUITABLE MEANS TO A RADIUS OF APPROXIMATELY 1/16 INCH OR EQUIVALENT FLAT SURFACE AT A SUITABLE ANGLE PRIOR TO PAINTING, GALVANIZING, OR METALLIZING.

HANDRAILS AND POSTS:

METAL STANDARDS AND FACES OF THE CONCRETE END POSTS FOR THE METAL RAIL SHALL BE SET NORMAL TO THE GRADE OF THE CURB, UNLESS OTHERWISE SHOWN ON PLANS. THE METAL RAIL AND TOPS OF CONCRETE POSTS USED WITH THE ALUMINUM RAIL SHALL BE BUILT PARALLEL TO THE GRADE OF THE CURB.

METAL HANDRAILS SHALL BE IN ACCORDANCE WITH THE PLANS. RAILS SHALL BE AS MANUFACTURED FOR BRIDGE RAILING. CASTINGS SHALL BE OF A UNIFORM APPEARANCE. FINISHES AND OTHER DEFORMATIONS RESULTING FROM CASTING OR OTHERWISE SHALL BE REMOVED IN A MANNER SO THAT A UNIFORM COLORING OF THE COMPLETED CASTING SHALL BE OBTAINED. CASTINGS WITH DISCOLORATIONS OR OF NON-UNIFORM COLORING WILL NOT BE ACCEPTED. CERTIFIED MILL REPORTS ARE REQUIRED FOR METAL RAILS AND POSTS.

SPECIAL NOTES:

GENERALLY, IN CASE OF DISCREPANCY, THIS STANDARD SHEET OF NOTES SHALL GOVERN OVER THE SPECIFICATIONS, BUT THE REMAINDER OF THE PLANS SHALL GOVERN OVER NOTES HEREON, AND SPECIAL PROVISIONS SHALL GOVERN OVER ALL. SEE SPECIFICATIONS ARTICLE 105-4.

ENGLISH

JANUARY, 1990

STD. NO. SN